

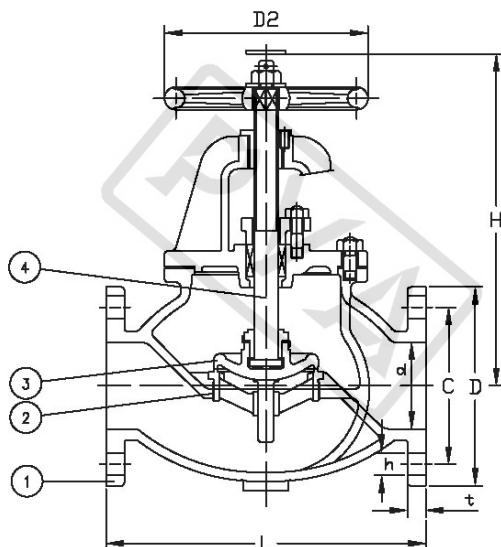

JISF7319 10K CAST STEEL GLOBE VALVE



Pressure Test		MPa	
Nominal Pressure/PN	1.0MPa	Shell Test	2.1 MPa
		Seat Test	1.54 MPa

Main material for fittings			
Item	Fittings	Material	Mark
1	Body	Cast Steel	SC230~450
2	Bonnet	Cast Steel	SC230~450
3	Disc	Stainless Steel/Cast Bronze	SS420/BC6
4	Seat	Stainless Steel/Cast Bronze	SS420/BC6
5	Stem	Stainless Steel/Forged Brass	SS400/C3771BD
6	Handwheel	Cast Iron	FC200

Main data for flange connection							mm
Model	Face To Face	Flange Diameter	Flange PCD	Flange Hole	Height	Weight	
	L	D	C	n* \varnothing d	H	kgs	
F7319 10K50	220	155	120	4 \times \varnothing 19	270	17.9	
F7319 10K65	270	175	140	4 \times \varnothing 19	300	26.0	
F7319 10K80	300	185	150	8 \times \varnothing 19	310	29.8	
F7319 10K100	350	210	175	8 \times \varnothing 19	355	44.7	
F7319 10K125	420	250	210	8 \times \varnothing 23	415	70.3	
F7319 10K150	490	280	240	8 \times \varnothing 23	470	96.4	
F7319 10K200	570	330	290	12 \times \varnothing 23	565	159.0	
F7319 10K250	740	400	355	12 \times \varnothing 25	645	257.0	
F7319 10K300	840	445	400	16 \times \varnothing 25	735	370.0	

Design	Check	Signature	Logo	Supplier
asbsey	Chrit	Figor		PROMET VALVES AUSTRALIA
JAN.01,2013	JAN.01,2013	JAN.01,2013		

PROMET VALVES AUSTRALIA

1A Green Road Woodville West SA 5011 Australia / Tel:+61 8 8268 1777 / Fax:+61 8 8268 1711
 promet@prometvalves.com / www.prometvalves.com / ABN47 096 425 697